

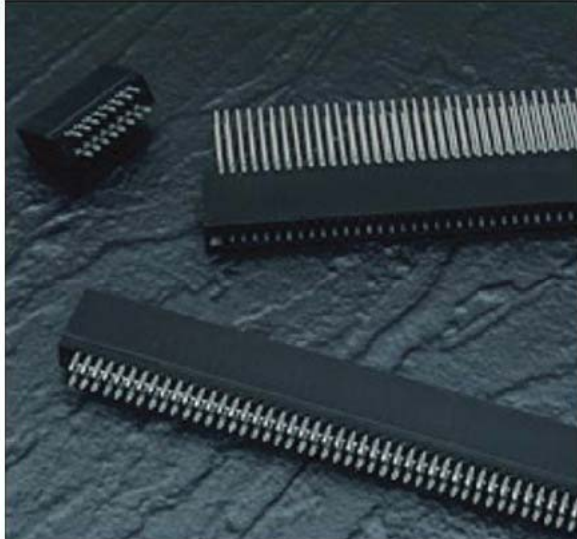

SERIES 717

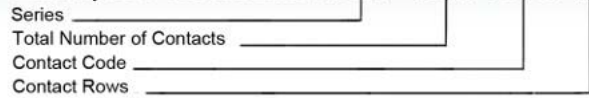

Example Part Number 717 - 044 - 520 - 206



Series 717

Total Number of Contacts	Contact Rows
005, 006, 043	Single Row
010, 012, 086	Dual Row

Contact Code	Description & Contact Point	Tail Length "G"
520	P.C. Tail Regular Point	.175 (4.45)
522	P.C. Tail Regular Point	.375 (9.53)
525	P.C. Tail High Point	.175 (4.45)
540	Wire Wrap Regular Point	.560 (14.22)
541	Wire Wrap Regular Point	.750 (19.05)
545	Wire Wrap High Point	.560 (14.22)

Contact Rows	Description
106	Single Row
206	Dual Row

Ordering Code Notes

- 1) All connector sizes up to 43 contacts single row / 86 contacts dual row are available upon request

SPECIFICATIONS

Insulator Material: Thermoplastic Polyester, UL 94V-O.

Colour: Black

Contact Material: Copper, Nickel, Tin Alloy, Phosphor Bronze

Contact Plating: 30 Microinches (0.76 Microns) Gold on the Mating Area, Tin on the Compliant Section and Contact Tails, Nickel Underplate. Other Plating Options Available Upon Request

Current Rating: 3 Amperes Continuous

Contact Resistance: 10 Milliohms Maximum

Dielectric Withstanding Voltage: 1800 V AC rms at Sea Level Between Adjacent Contacts

Insulation Resistance: 5000 Megohms Minimum

Operating Temperature: -65 to +105 Degrees C

Daughter Board Insertion Force: 16oz (4.45N) Maximum per Contact Pair when Tested with a .070 (1.78) Thick Gauge

Daughter Board Withdrawal Force: 1 oz. (0.28N) Minimum per Contact Pair when Tested with a .054 (1.37) Thick Gauge

Contact Insertion Into Hole: 20lbs (89 N) Maximum

Contact Retention In Hole: 10lbs (44N) Minimum

Re-Insertability of Hole: 3 Times Minimum

FEATURES

UL Recognized

.156 (3.96) Contact Spacing x .200 (5.08) Row Spacing

Accepts .062 (1.57) Nominal Thickness P.C. Board

High Profile Insulator Body, .550 (13.97)

Ultra-Mate Compliant Section for Gas-Tight Reliable Connection in Plated Through Holes Eliminates Soldering Operations

Contact Termination Options include P.C Tail and .025 (0.64) Square Wire Wrap

Single or Dual Row Configurations

Accepts Between and In-Contact Polarizing Keys

Tools Available for Insulator and Contact Removal. Simple "Flat Rock" Tooling is Used for Connector Installation

Series 717

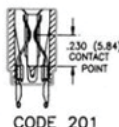

IN-CONTACT
POLARIZING KEY

BETWEEN CONTACT
POLARIZING KEY

P/N 745-240-328

P/N 306-240-318



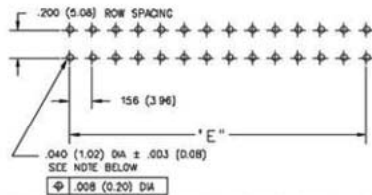
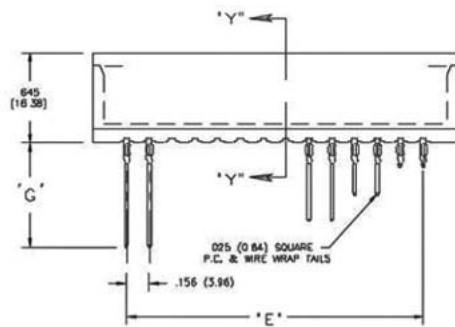
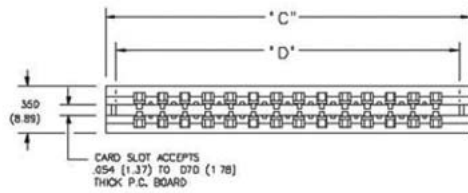

RECOMMENDED MOTHER BOARD HOLE PATTERN

TO OBTAIN OPTIMUM COMPLIANT SECTION PERFORMANCE,
 DRILL HOLES D453 ± .001 (1.15 ± 0.03) DIAMETER
 COPPER PLATE, .501 (25.4 MICRONS) MINIMUM THICKNESS,
 FOLLOWED BY TIN PLATE TO PROVIDE FINISHED
 HOLES D40 ± .003 (1.02 ± 0.08) DIAMETER

SECTIONS "Y" - "Y" CONTACT ROW OPTIONS

Single Row Version, Code 106, May Require Backup Springs Depending on the Application Consult with EDAC for Details.

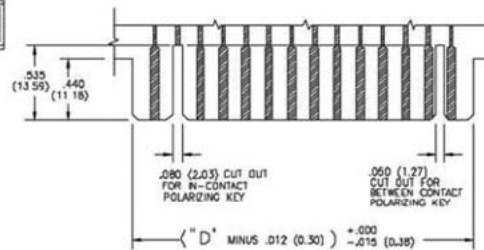
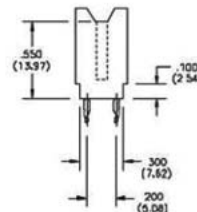
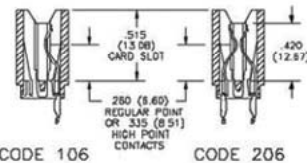

RECOMMENDED DAUGHTER BOARD

NUMBER OF CONTACTS		"C"		"D"		"E"	
Single	Dual	Inch	(mm)	Inch	(mm)	Inch	(mm)
5	10	1.246	(31.65)	1.100	(27.94)	.780	(19.81)
6	12	1.402	(35.61)	1.256	(31.90)	.906	(23.77)
10	20	2.026	(51.46)	1.880	(47.75)	1.560	(39.62)
15	30	2.806	(71.27)	2.660	(67.56)	2.340	(59.44)
18	36	3.274	(83.16)	3.128	(79.45)	2.808	(71.32)
20	40	3.586	(91.08)	3.440	(87.38)	3.120	(79.25)
22	44	3.898	(99.01)	3.752	(95.30)	3.432	(87.17)
25	50	4.366	(110.90)	4.220	(107.19)	3.900	(99.06)
28	56	4.834	(122.78)	4.688	(119.08)	4.368	(110.95)
30	60	5.146	(130.71)	5.000	(127.00)	4.680	(118.87)
31	62	5.302	(134.67)	5.156	(130.98)	4.836	(122.83)
33	66	5.614	(142.60)	5.468	(138.89)	5.148	(130.76)
36	72	6.082	(154.48)	5.936	(150.77)	5.616	(142.65)
43	86	7.174	(182.22)	7.028	(178.51)	6.708	(170.38)

Dimensions of Other Connector Sizes are Listed

Mouser Electronics

Authorized Distributor

Click to View Pricing, Inventory, Delivery & Lifecycle Information:

EDAC:

[717-006-520-201](#) [717-056-520-201](#) [717-056-541-201](#)